

Z8 Speaks

Real-time Embedded Systems, George Washington University, Spring 2006

Duoduo Liao

Project Abstract

This purpose of this project was to create a Z8 speaks like a talking robot. The system is mainly composed of Z8 microcontroller board, VoiceDirect speech recognition board, SpeakJet speech synthesis chip, real-time clock, and temperature sensor. The user can interact with the Z8 Speaks through speech communication based on speech recognition and synthesis. It has the capabilities to display current temperature, time, calendar, name, music, reset, and other information on the LEDs in the Z8 board upon spoken request as well as speaking corresponding information. This project provides 12 different operations, such as temperature, time, calendar, reset, music, etc., which have been already set well in the program. Before the user talks with the robot, his or her voice commands need to be trained correspondingly for the preset operations and stored as speech patterns. Then the user can ask the questions for the robot. If the voice does not match any of trained voice commands, a speech instruction will be given to allow the user to try again.

Final Project

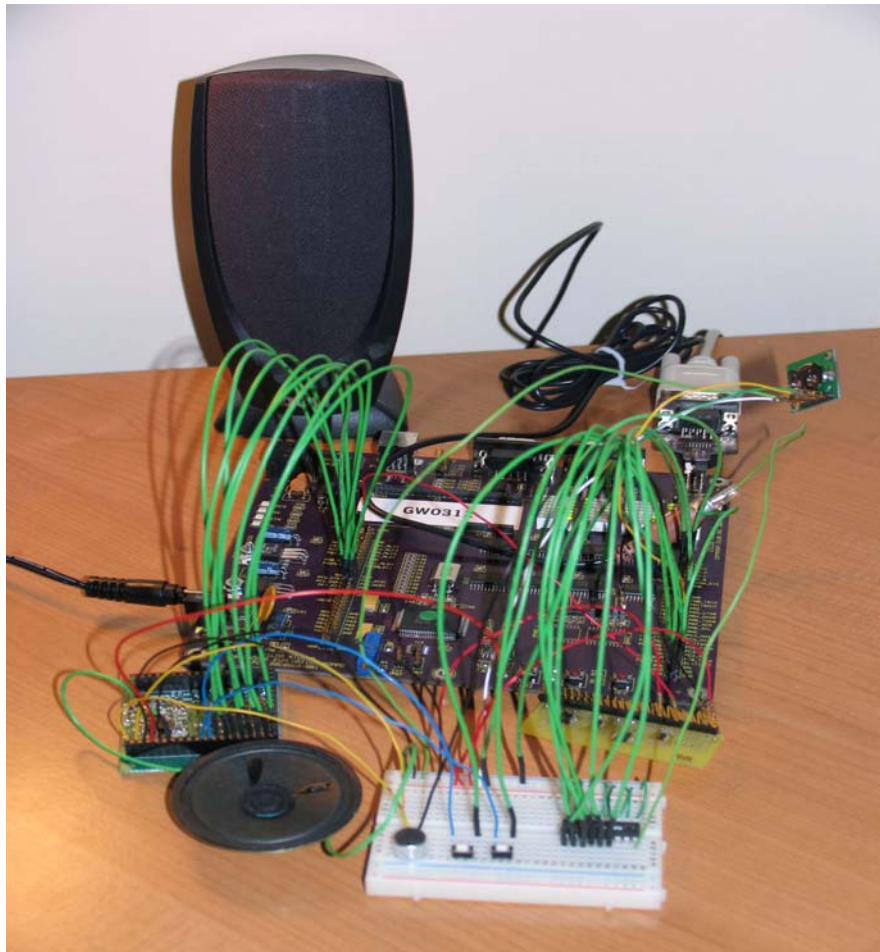

Project Demonstration Video (13MB):

http://home.gwu.edu/~dliao/cs339/Liao_z8Speaks_320x240.mpg

Work in progress/Disgram/Schematic

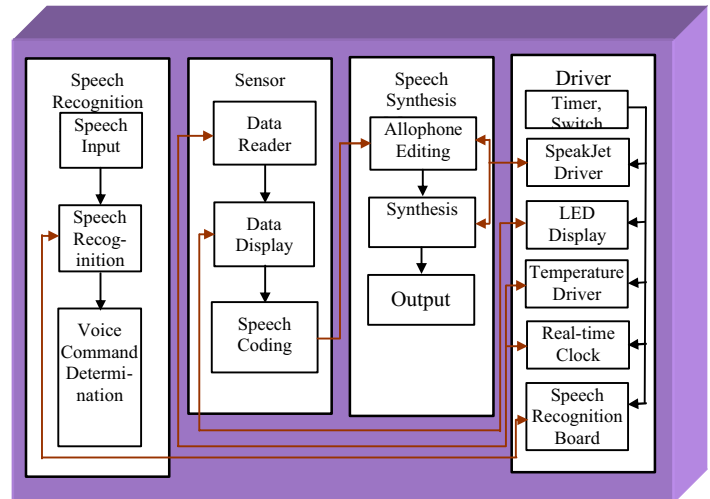
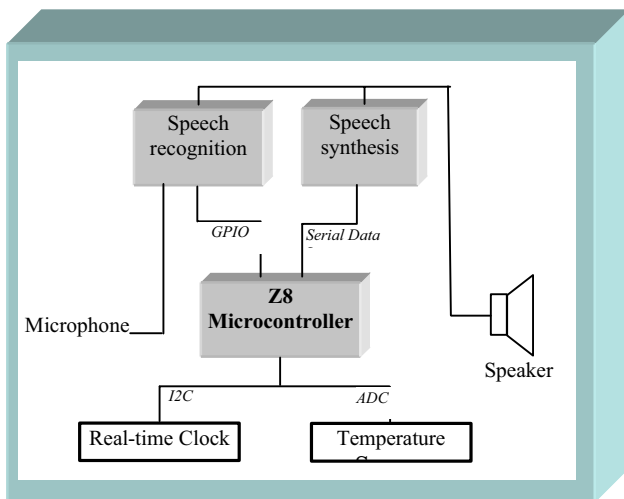
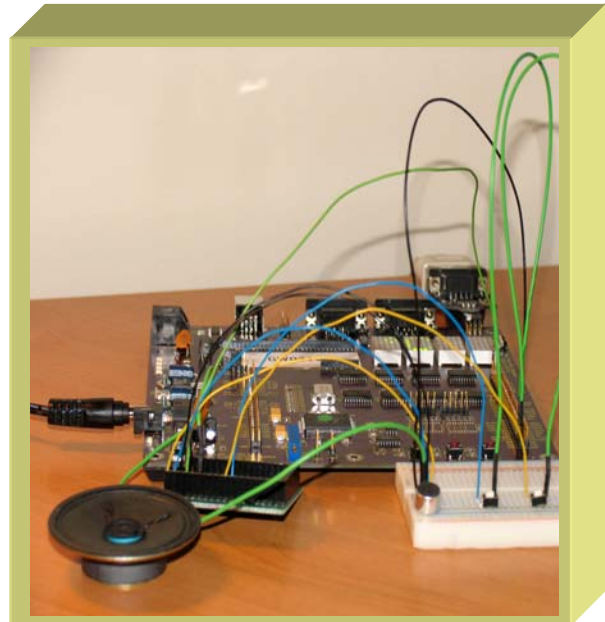
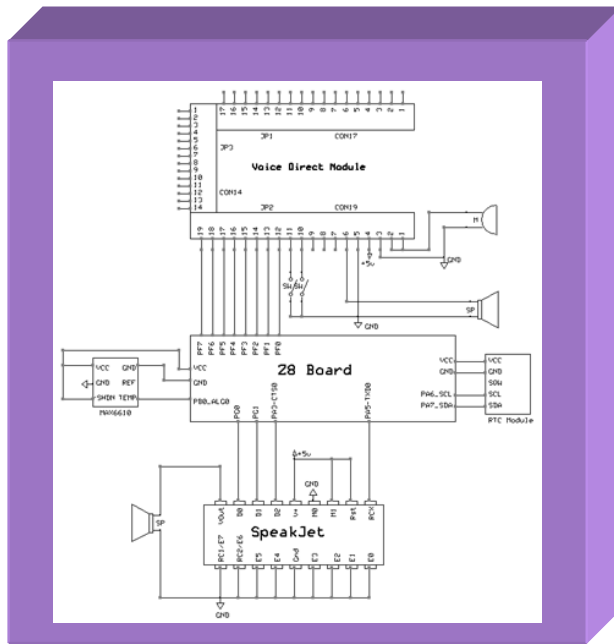

Lesson Learned

- Hardware design and prototyping
- Z8 programming
- Speech recognition board use and development
- Speech synthesis chip use and development
- I2C control of Real-time Clock
- ADC control of temperature sensor