

Wireless 1-Wire Control Network

Real-Time Embedded Systems, The George Washington University, Spring 2006
Keevan Simmonds (kwsimmonds@hotmail.com)

Project Abstract

This project is a wireless 1-Wire control network. It is specifically a wireless temperature sensor. Two Zilog Z8F6403 microcontrollers are used in a master/slave fashion. The master is the controller that is connected to a PC. It links to the slave via a Linx TR-916-SC-PA wireless transceiver module. The slave microcontroller is connected to a 1-Wire network that incorporates a switch and a temperature sensor. The slave will toggle the switch and/or get the current temperature on command from the master. The result of the toggle and/or the current temperature is sent back to the master via the wireless transceiver and displayed on the PC terminal.

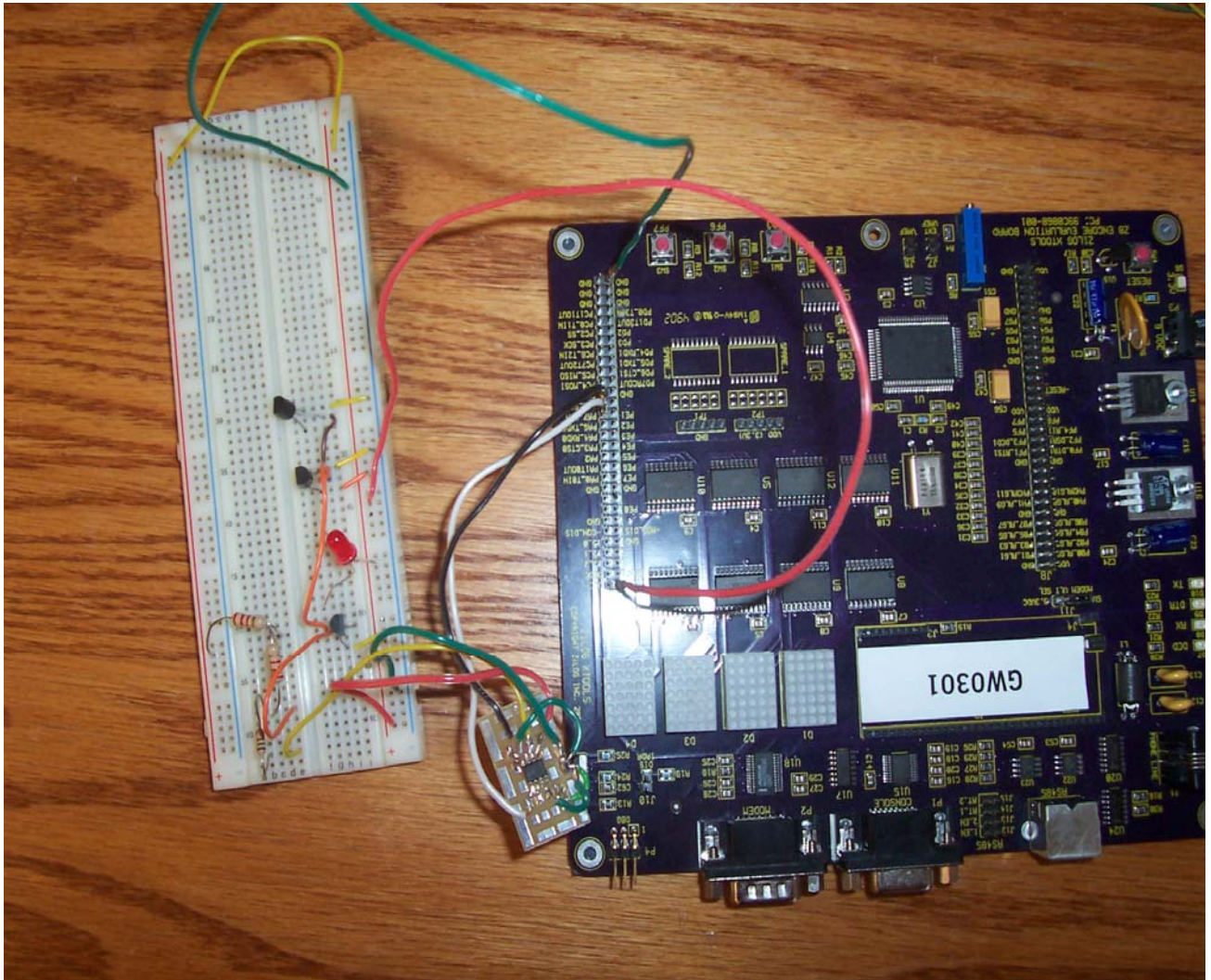

Work In Progress/Schematic/Diagram

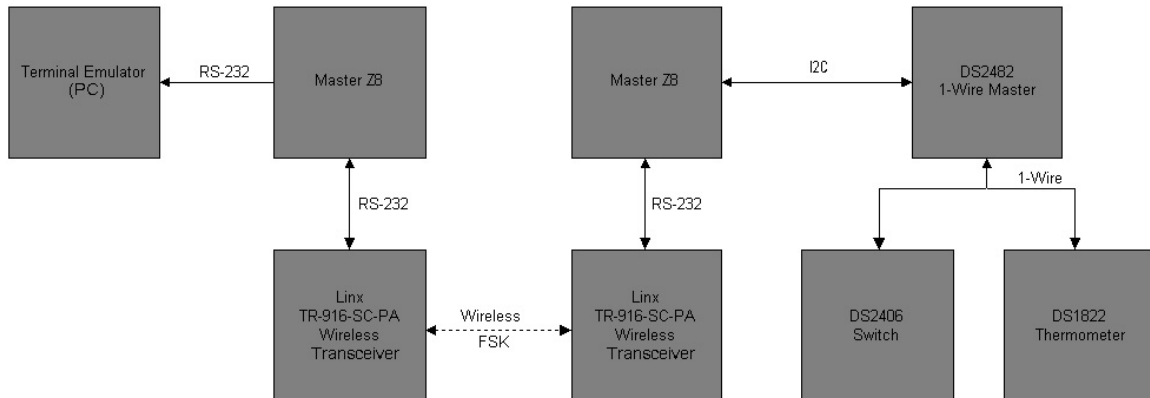

Lessons Learned

- Zilog Z8 programming
- Zilog UART implementation
- I²C bus
- 1-Wire bus
- Reliable wireless communication